

1- Overview

Stepper : Switec X27-589

- Maximum operating speed : 600°/s
- 0,5° per full step
- Angle of rotation with internal stop : 315°
- Operating voltage : 5V to 9V
- Coil resistance (per coil) : 260Ω @ 5V / 290Ω @ 9V

Measurements :

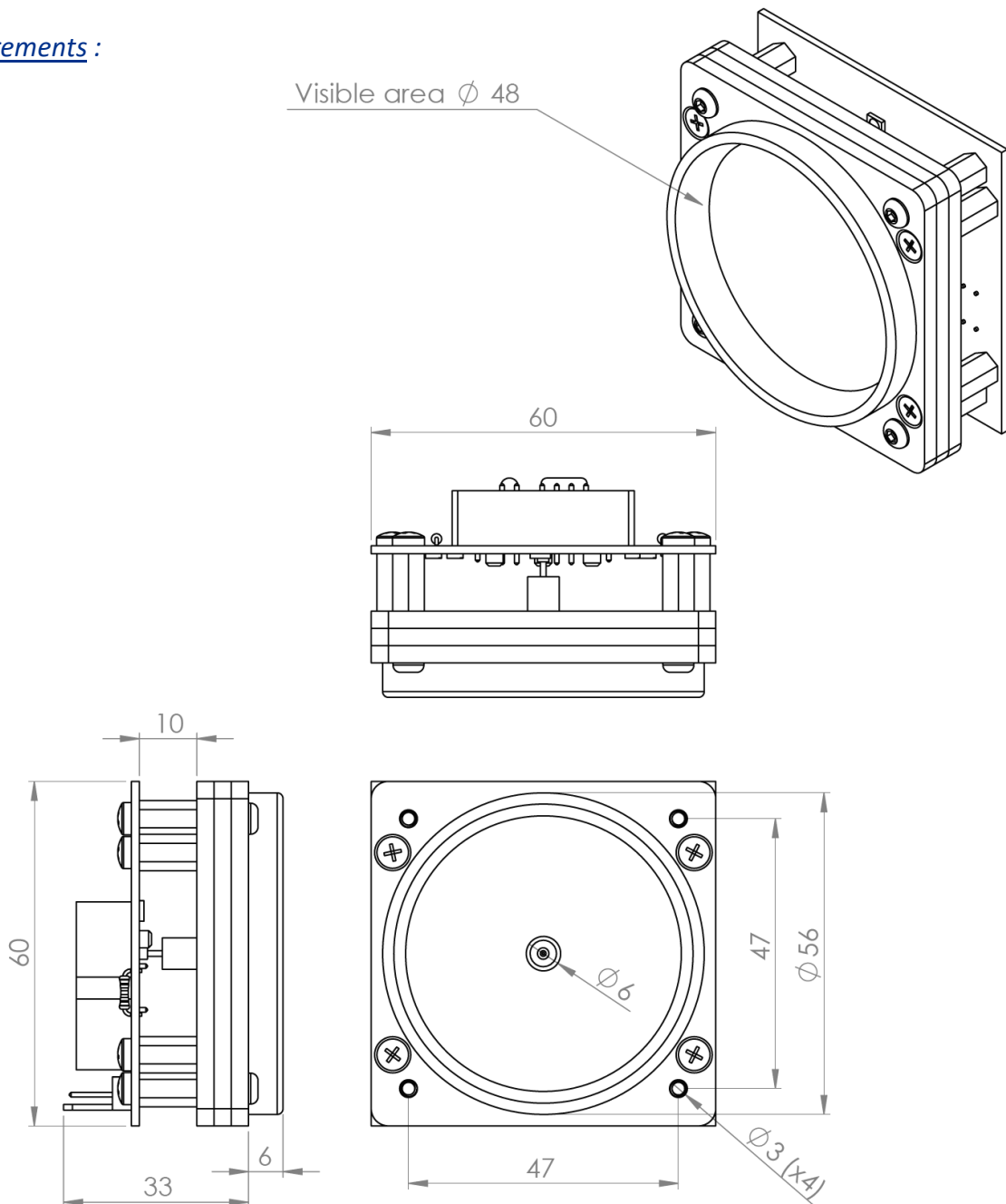

2- Kit content

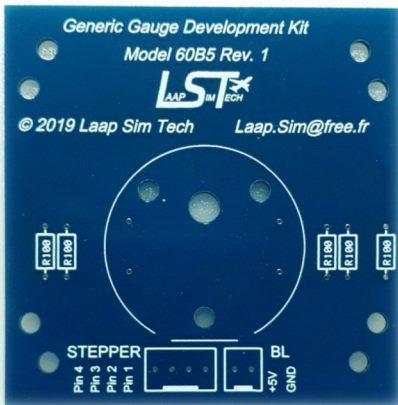

PCB (x1)

*Differs depending
backlight voltage*

*Please refer to the
PCB assembly manual*

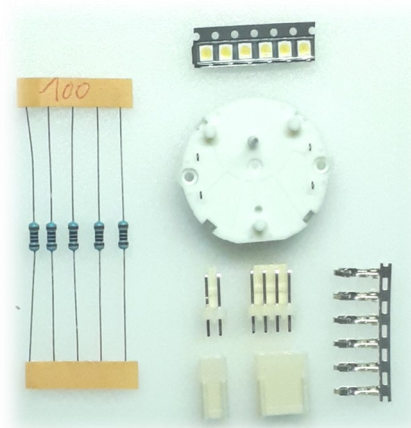

Components set

*Differs depending
backlight voltage*

*Please refer to the
PCB assembly manual*

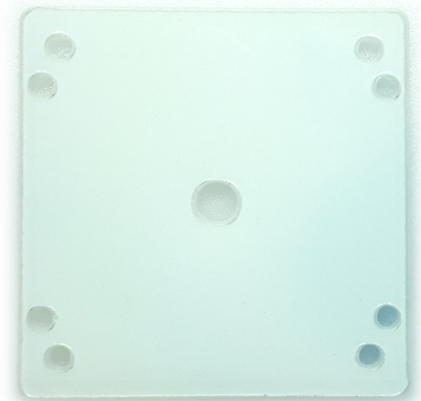

Diffusing PMMA sheet (x1)



Middle plate (x1)



Glass (x1)



Front bezel (x1)

M3x16
black
hex screws
(x4)



M3x10
hex spacers
(x8)

M3x12
countersunk
screws
(x4)



M3x6
screws
(x8)



Needle
(x1)

White sticker
(x1)

Black sticker
(x1)

3- Gauge assembly

It's recommended to follow these steps in the order of the manual.

PMMA laser cut parts may have a transparent protection film. Please ensure to remove it on both sides before assembly.

The components must be soldered, please refer to the PCB manual.

3a- Spacers

Screw the 8 hex spacers on the PCB using M3x6 screws. Do not overtighten.

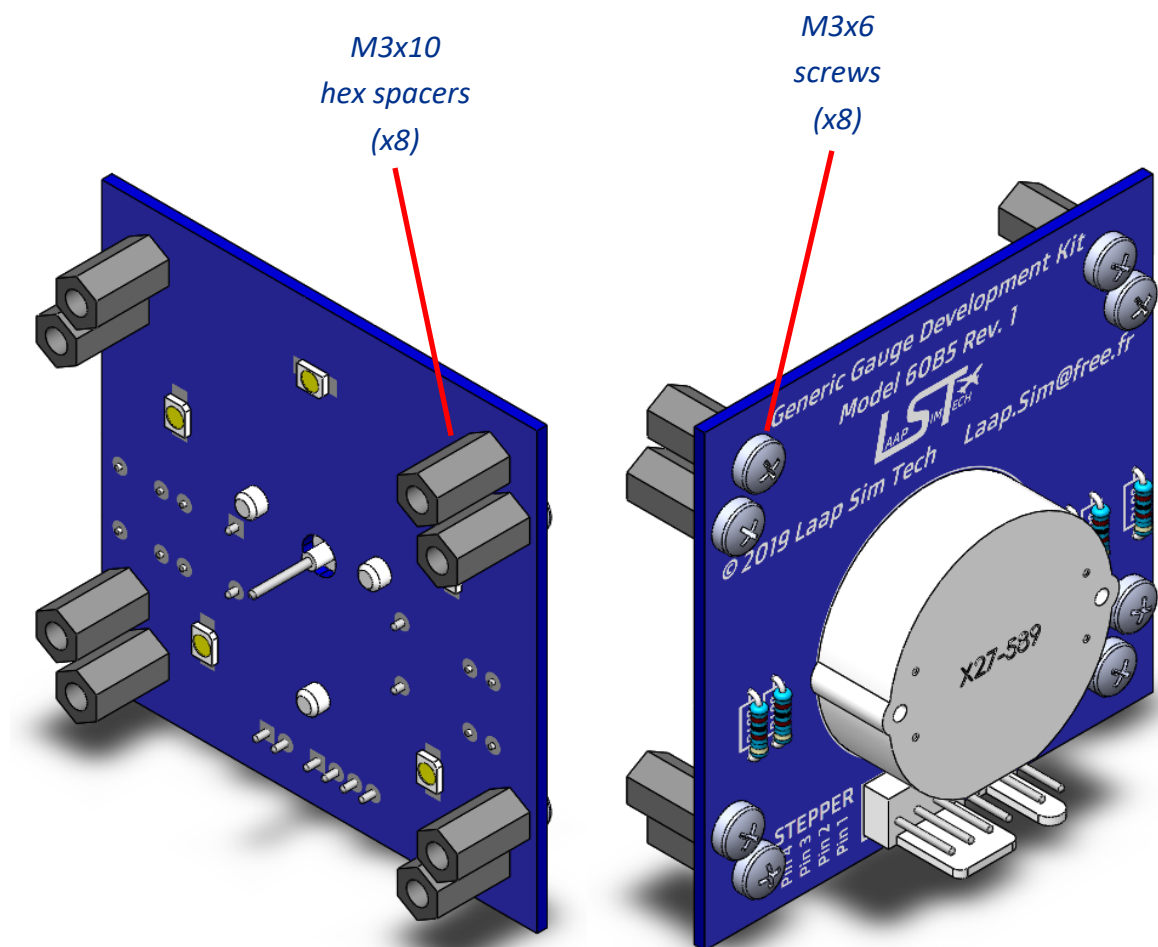

3b- Needle stickers

- Place the white sticker carefully on the needle, and remove the adhesive film.
- Place the black sticker on the needle. You can use tweezers to be more precise.

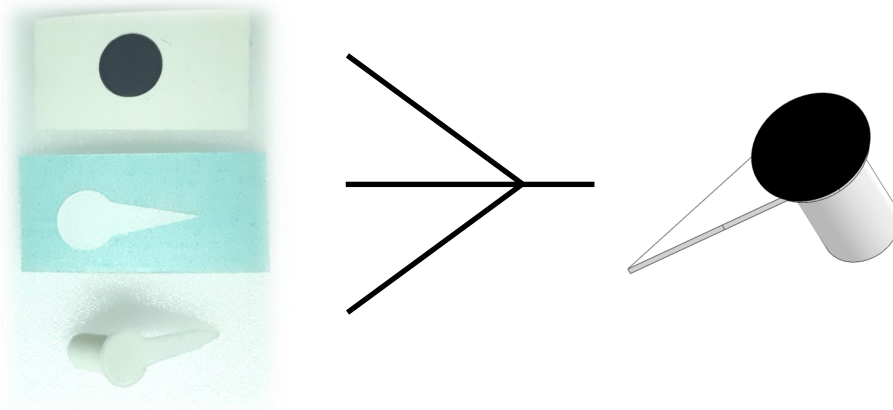

3c- Printed pattern

If you didn't order the optional pattern, you have to print, glue on diffusing plate and drill it. It's recommended to use a glue spray to keep the pattern as dry as possible.

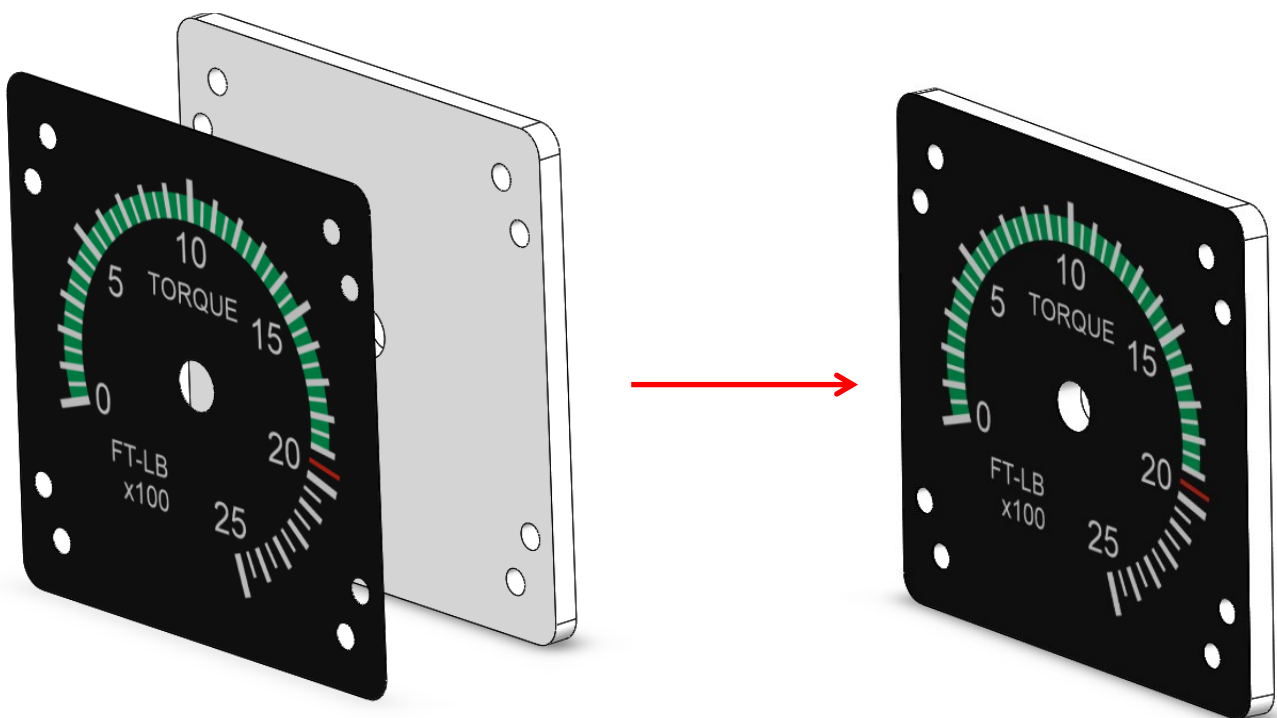

3d- Final assembly

Make sure the stepper shaft is turned at its leftmost position.

You can now assemble all the parts together, from back to front.

Use the four M3x12 countersunk screws to fix all these parts on the hex spacers.

1

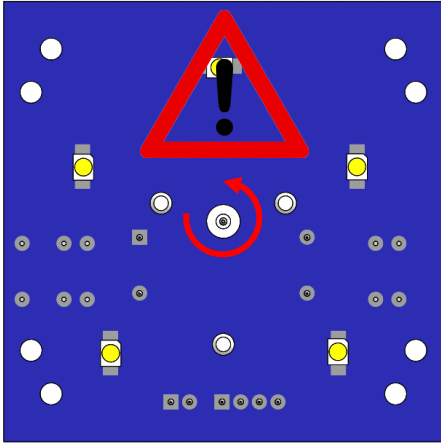

2

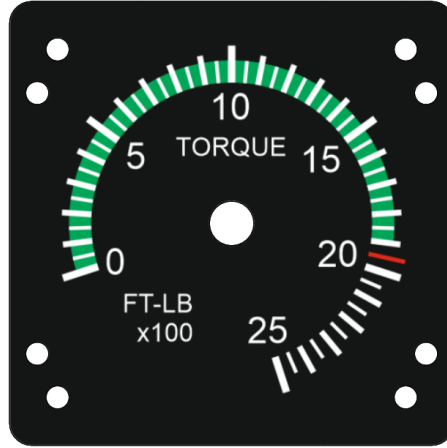

3

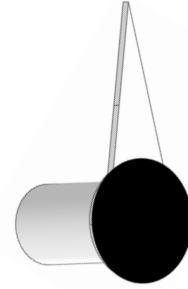

4

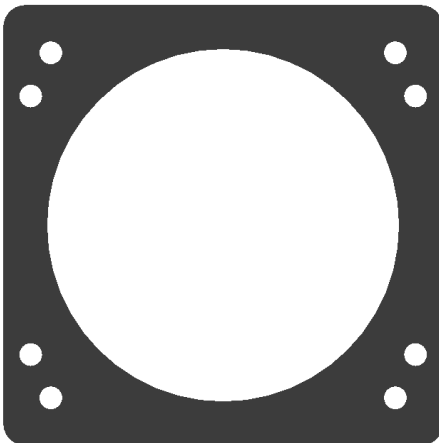

5



6

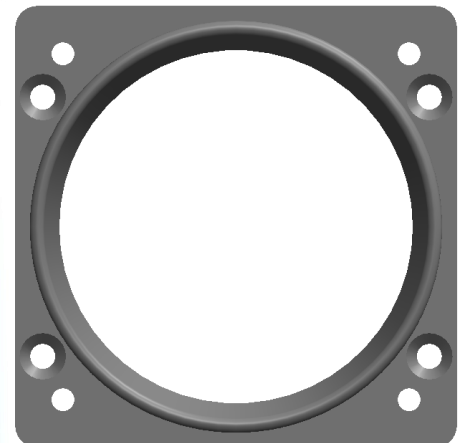

7



M3x12
countersunk screws (x4)

Exploded view :

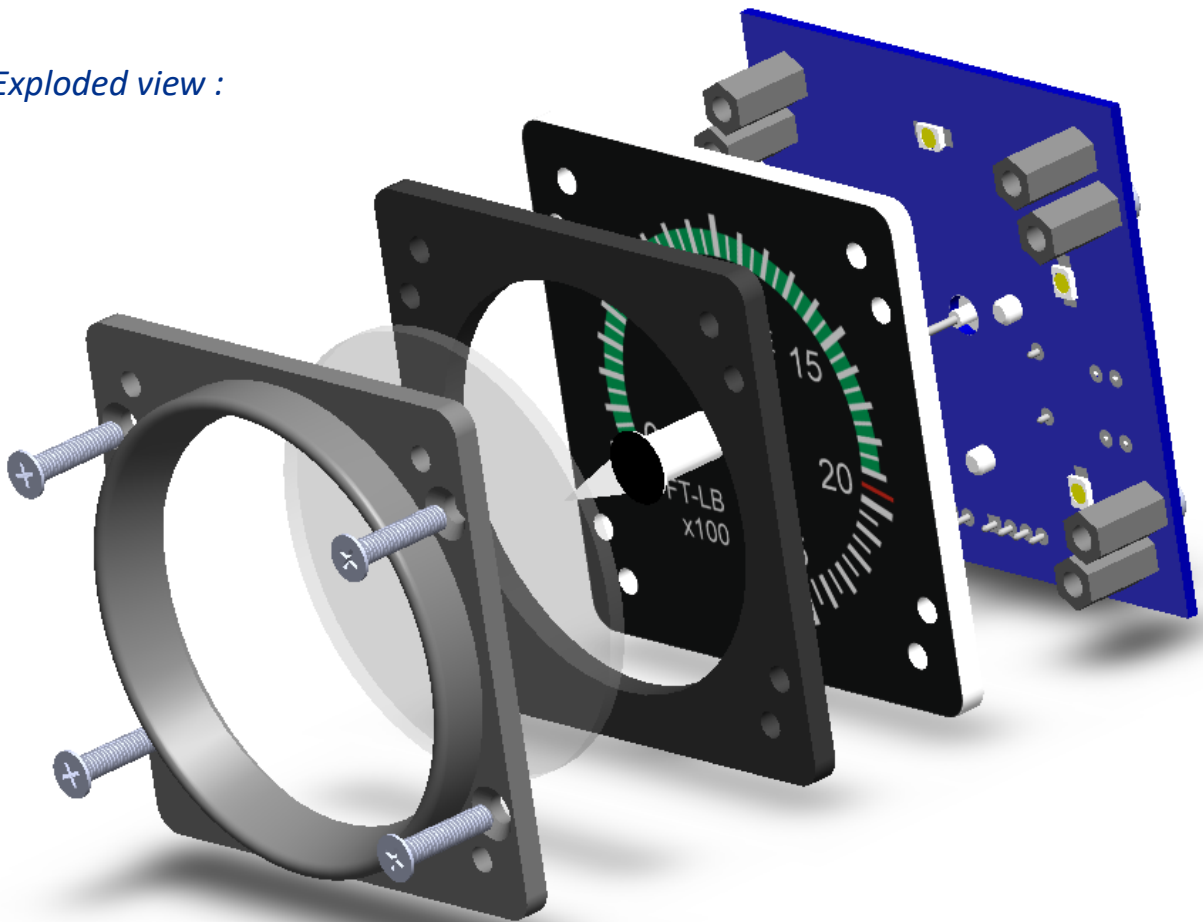

3e- Panel mount

M3x16 black hex screws are provided to mount the gauge on your own panel.

